

Auxilliary Power Units

STEYRMOTORS
AUSTRALIA 

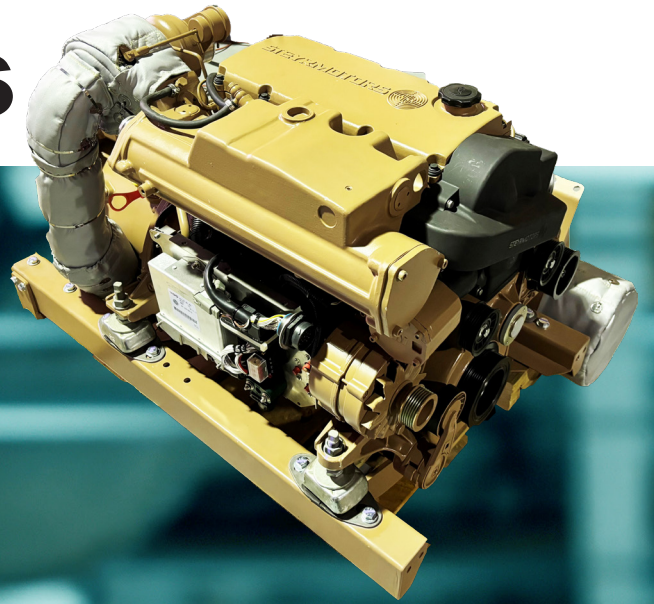

Sustainable Innovation

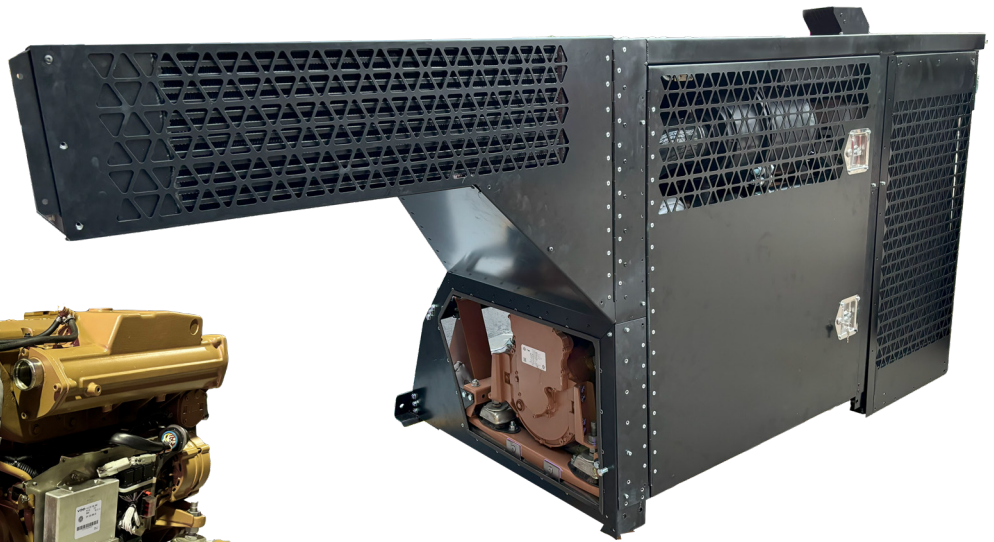
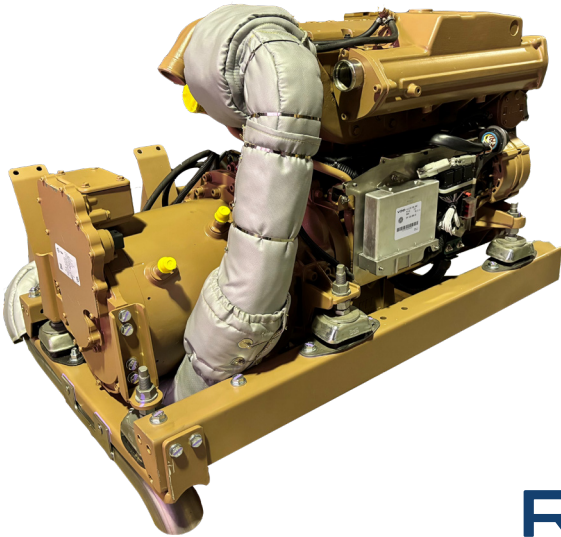

Multi-fuel ✓
Customisable ✓
Range Extender ✓



Dedicated Team

Customer focused team capable of providing solutions.



Technical Experts

Experienced staff with extensive inhouse engineering expertise.



Design Capability

Design experience across a wide range of platforms.



Extensive Portfolio

Design experience across a wide range of platforms.

Engine Variants

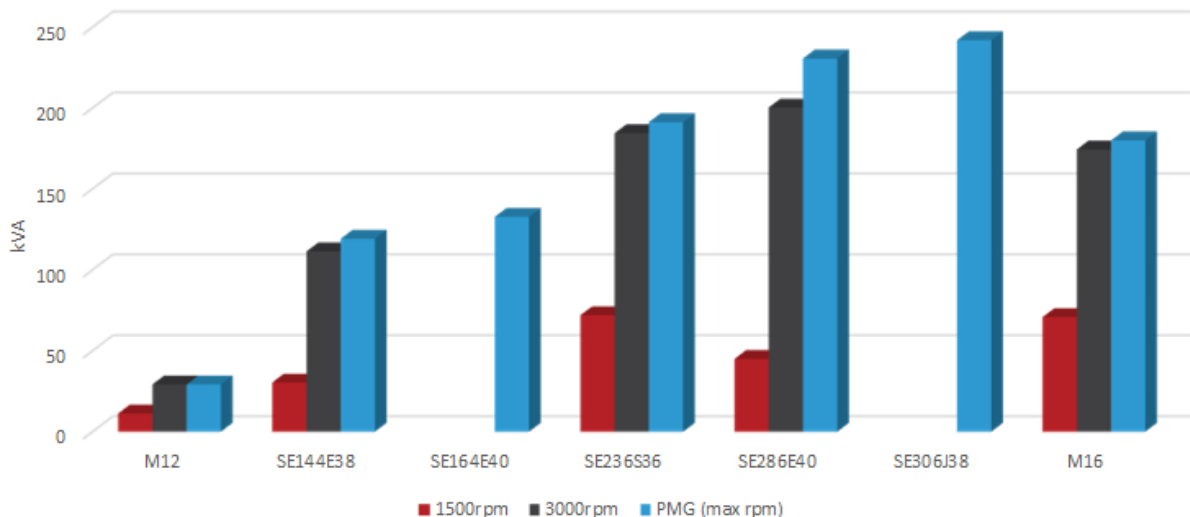

* Calculated Engine Capability

APU

AUXILLIARY POWER UNITS

Our Heavy Vehicle Auxiliary Power Units (APUs) are engineered for demanding defense applications, providing a versatile and reliable power solution tailored to your operational requirements. These self-contained diesel-electric generators are customisable, delivering between 25kW and 170kW of electrical power, depending on the engine size. Designed to perform in the most extreme conditions, our APUs ensure your vehicles remain fully operational during critical missions. Whether for low-power needs in smaller vehicles or high-output demands in larger systems, our APU solutions offer unmatched durability and adaptability for defense operations.

- ➔ Monoblock design with excellent water cooling
- ➔ Turbocharged, intercooled
- ➔ Mass balancing system for smooth operation
- ➔ Multifuel capable
- ➔ Operational temperature range*: from -46 °C to +49 °C

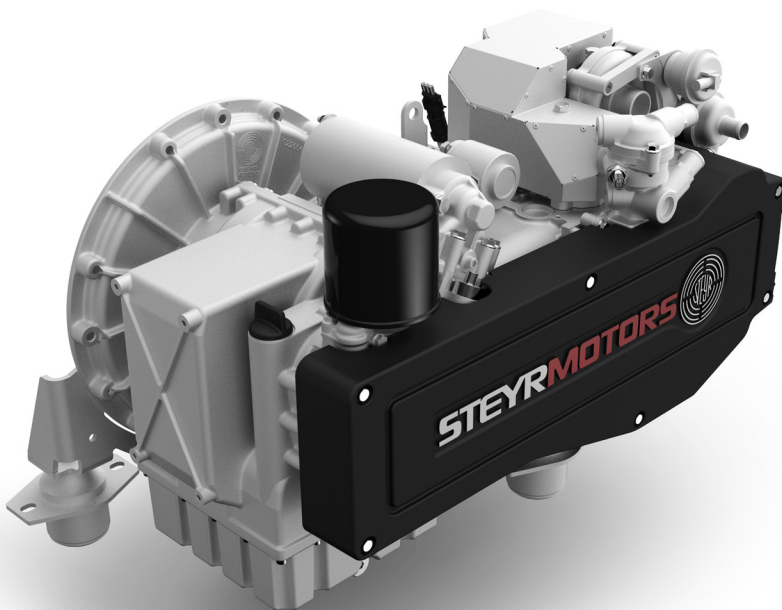

Overview

- Customisable Power Output
- Self-Contained System
- Seamless Integration
- Robust Performance
- Compact Design
- Defence-Grade Durability
- Flexible Compliance
- Comprehensive Documentation

[2] 25kW
CYLINDER

[4] 95kW
CYLINDER

[6] 170kW
CYLINDER

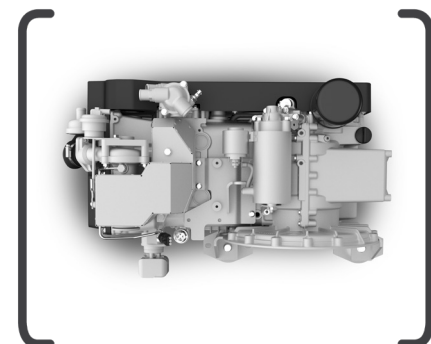
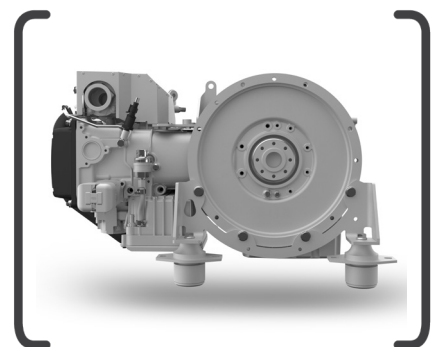



Contact us

PHONE +61 7 3356 9808 | **EMAIL** info@steyr-motors.com.au
www.steyr-motors.com.au

33 Stone Street, Stafford QLD 4053 Australia

